

# *HFA U-SLIDE information/dimension sheet*

*Phone : 815-943-1195 Fax : 815-943-4030 Email : [john@hfaconveyors.com](mailto:john@hfaconveyors.com) or [dennis@hfaconveyors.com](mailto:dennis@hfaconveyors.com)*

**Customer Information:**

**Name:** \_\_\_\_\_ **Ph:** \_\_\_\_\_

**Company:** \_\_\_\_\_ **Fx:** \_\_\_\_\_

**Address:** \_\_\_\_\_ **Email:** \_\_\_\_\_

**City/State/Zip:** \_\_\_\_\_

*\*Front View*

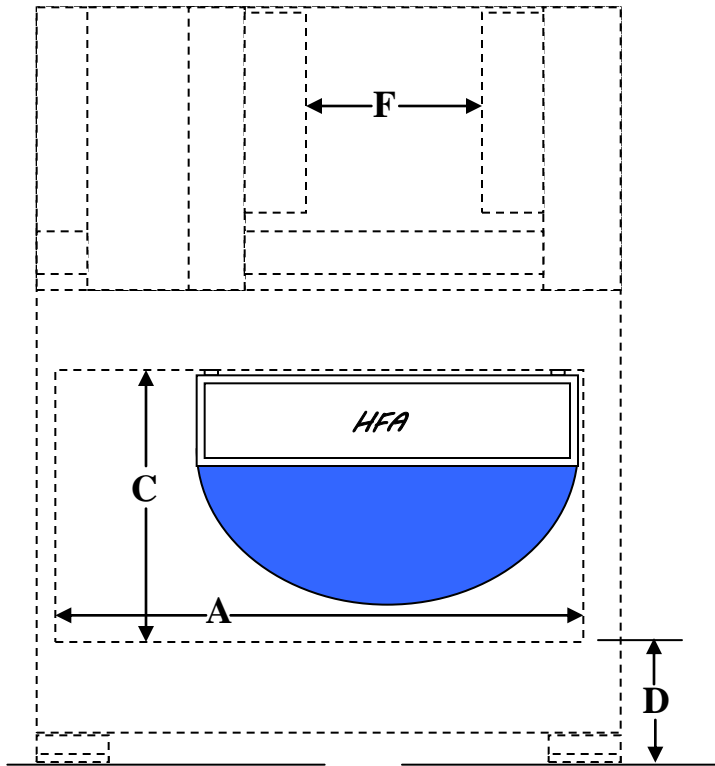

*\*Side View*

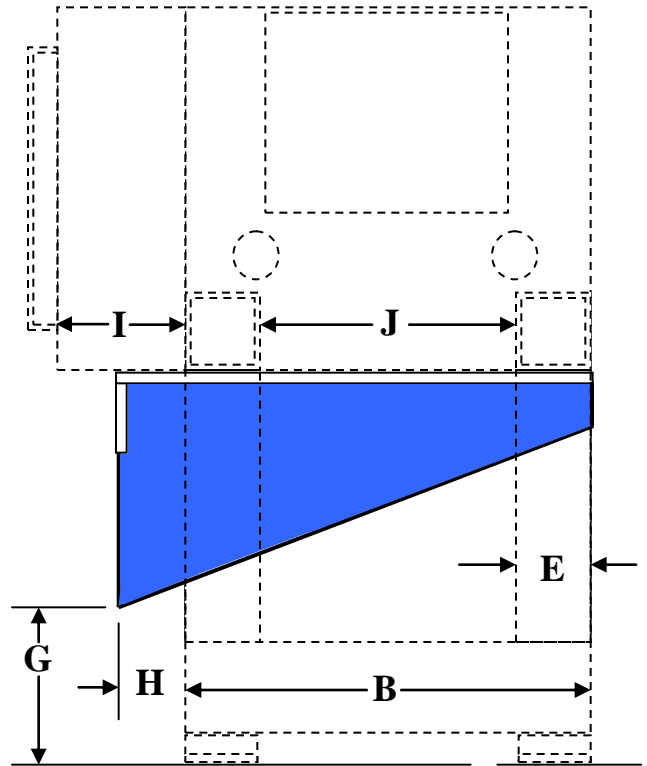

***Press # (and/or) Model*** \_\_\_\_\_

**A** (width of opening) = \_\_\_\_\_ **B** (press base width) = \_\_\_\_\_ **C** (height of opening) = \_\_\_\_\_

**D** (press base height) = \_\_\_\_\_ **E** (width of frame) = \_\_\_\_\_ **F** ("working" mold open) = \_\_\_\_\_

**G** (discharge height needed) = \_\_\_\_\_ **H** (distance needed past base) = \_\_\_\_\_

**I** (overhang of press) = \_\_\_\_\_ **J** (width between frame) = \_\_\_\_\_

**UHMW "chute" color (check one)...choice of *Blue* \_\_\_\_\_ or *White* \_\_\_\_\_**